

# SuperStack® 3 Switch 4400 1000BASE-SX Module (3C17221) User Guide

DUA1722-1AAA01

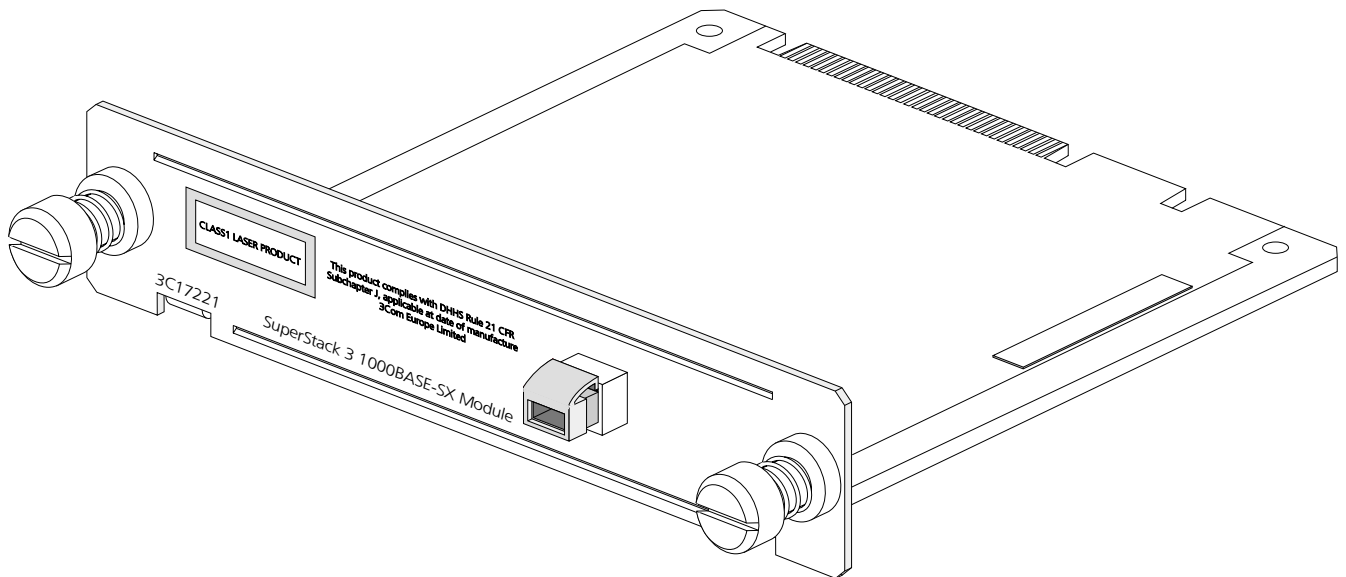

## INTRODUCTION

The SuperStack® 3 Switch 4400 1000BASE-SX Module (3C17221) provides your SuperStack 3 Switch 4400 with one 850 nm Gigabit Ethernet fiber optic port.

The Module conforms to the full duplex implementation of the Gigabit Ethernet standard, IEEE 802.3z, and provides a 1000 Mbps connection to another 1000BASE-SX device. This port uses 62.5  $\mu\text{m}$  or 50  $\mu\text{m}$  multimode fiber optic cable with MT-RJ duplex connectors and supports the segment lengths specified in IEEE 802.3z, as shown below:

Fiber Size	Fiber Bandwidth at 850 nm	Segment Lengths Supported
62.5 $\mu\text{m}$	160 MHz*km	2–220 m (7–722 ft)
	200 MHz*km	2–275 m (7–902 ft)
50 $\mu\text{m}$	400 MHz*km	2–500 m (7–1805 ft)
	500 MHz*km	2–550 m (7–1805 ft)

### LEDs

You can gather information about the status of the Module and its packet activity using the Expansion Module port LEDs on the front of the Switch.

#### Module Packet LED

Color	Appearance	Indicates
Green	On	Full duplex activity being received or transmitted.
No color	Off	No activity.

#### Module Status LED

Color	Appearance	Indicates
Green	On	The Module is installed and supported. The Link Status has been determined.
Yellow	On	The Module is installed and supported. The Link Status has not been determined or there is no link for a single port Module.
Yellow	Flashing	The Module is installed, however, it is not supported.
No color	Off	The Module is not installed.

# SAFETY INFORMATION



**WARNING:** Installation and removal of the Module must be carried out by qualified personnel only. Before installing the Module into a unit, you must first disconnect the unit from the mains power supply. For full safety instructions, refer to the user guide that accompanies the unit.



**AVERTISSEMENT:** Confiez l'installation et la dépose de ce Module à un personnel qualifié. Avant d'installer ce Module dans un groupe, vous devez au préalable débrancher ce groupe de l'alimentation secteur. Pour prendre connaissance des consignes complètes de sécurité, consultez le guide utilisateur qui accompagne ce groupe.



**WARNHINWEIS:** Die Installation und der Ausbau des Moduls darf nur durch Fachpersonal erfolgen. Vor dem Installieren des Moduls in einem Gerät muß zuerst der Netzstecker des Geräts abgezogen werden. Vollständige Sicherheitsanweisungen sind dem Benutzerhandbuch des Geräts zu entnehmen.



**WARNING:** When the Module is inserted into the switch, the captive screws securing the Module must be tightened with a suitable tool. Keep the blanking plate and the fixings in a safe place. If you remove the Module at any time, you must then replace the blanking plate.



**AVERTISSEMENT:** Quand le Module est inséré dans le commutateur, visser le module, en le sécurisant fortement avec un outil adapté. Conservez la plaque d'obturation et les fixations en lieu sûr. Si vous retirez le Module à tout instant, vous devez alors replacer la plaque d'obturation.



**WARNHINWEIS:** Beim Einsetzen des Moduls in dem Switch sind die unverlierbaren Schrauben mit einem passenden Werkzeug festzuziehen. Die Distanzplatte und die Befestigungselemente an einem sicheren Ort aufbewahren. Beim Austausch des Moduls ist auch die Distanzplatte zu ersetzen.



**WARNING: Fiber Optic ports - Optical Safety**



Never look at the transmit laser while it is powered-up. Never look directly at the fiber TX port and fiber cable ends when they are powered-up.



**WARNING:** Use of controls or adjustments of performance or procedures other than those specified herein may result in hazardous laser emissions.



**AVERTISSEMENT: Ports pour fibres optiques - sécurité sur le plan optique**



Ne regardez jamais le laser tant qu'il est sous tension. Ne regardez jamais directement le port TX (Transmission) à fibres optiques et les embouts de câbles à fibres optiques tant qu'ils sont sous tension.



**AVERTISSEMENT:** L'utilisation de contrôles, de réglages de performances ou de procédures autres que ceux qui sont spécifiés au sein du présent document risquent d'entraîner l'exposition à des rayonnements laser dangereux.



**WARNHINWEIS: Faseroptikanschlüsse - Optische Sicherheit**



Niemals ein Übertragungslaser betrachten, während dieses eingeschaltet ist. Niemals direkt auf den Faser-TX-Anschluß und auf die Faserkabelenden schauen, während diese eingeschaltet sind.



**WARNHINWEIS:** Die Verwendung von Steuerelementen oder die Anpassung von Leistungen und Verfahren in anderer als der hierin genannten Weise kann zu gefährlichen Laseremissionen führen.

# INSTALLATION AND REMOVAL

## Handling the Module

The Module can be easily damaged by electrostatic discharge. To prevent damage, observe the following:

- Always wear an anti-static wristband connected to a suitable earth point.
- Do not remove the Module from its packaging until you are ready to install it into a Switch.
- Do not touch any of the pins, connections or components on the Module.
- Handle the Module only by its edges and front panel.
- Always store or transport the Module in anti-static packaging.

## Installing the Module into a Switch



**CAUTION:** This Module is not hot-swappable. Always make sure that the Switch is powered down and disconnected from the mains before installing or removing a Module. Use the following instructions when installing or removing a Module.



Each Switch has the facility to accept up to two Expansion Modules, allowing Cascade, Gigabit Ethernet or Fast Ethernet connections. Modules can be inserted into either Expansion Module slot.

**Figure 1** Inserting the Module into the Switch

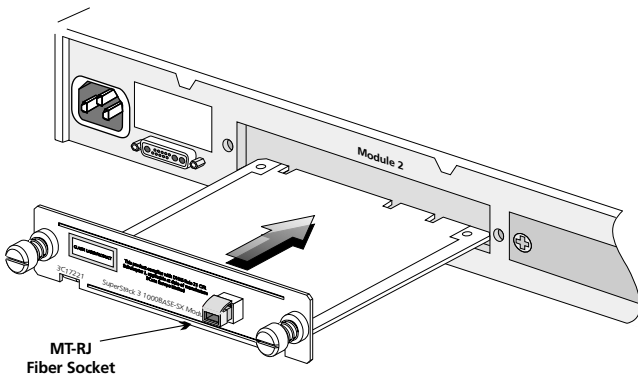

To install the Module:

- 1 Ensure that the Switch is disconnected from the mains power supply and that you are wearing an anti-static wristband connected to a suitable earth point.
- 2 Undo the two screws securing the blanking plate at the rear of the Switch using a suitable screwdriver. Do not remove any other screws from the rear of the Switch.
- 3 Remove the blanking plate.
- 4 Hold the Module so that the text on the front panel is upright and insert it into the Switch, ensuring the connectors are fully engaged (see [Figure 1](#)). Make sure the Module is pushed fully in.
- 5 Secure the Module by tightening the two captive screws with a screwdriver.



Keep the blanking plate and screws in a safe place. If you remove the Module at any time, you must replace the blanking plate to prevent dust and debris entering the Switch. Replacing the blanking plate will also help circulate cool air through the Switch.

## Activating the Module

- 1 Ensure that the Switch is powered-up.
- 2 Remove the protective stopper from the MT-RJ fiber socket on the Module. Squeeze the top and bottom of the stopper between your thumb and forefinger then remove it.
- 3 Plug the MT-RJ connector on the fiber cable into the MT-RJ fiber socket on the Module.
- 4 Connect the other end of the fiber optic segment to a device fitted with a 1000BASE-SX connection.
- 5 Check the LEDs on the front of the Switch to ensure that the Module is operating correctly. Refer to [“LEDs”](#) for more information.

## Removing the Module from a Switch

- 1 Ensure that the power supply and the fiber backbone connection cables are disconnected from the Switch.
- 2 Undo the Module's two captive screws with a suitable screwdriver. Do not remove any other screws from the Switch.
- 3 Remove the Module.
- 4 If you are not fitting another Module immediately, you must replace the blanking plate to ensure that dust and debris do not enter the Switch. Replacing the blanking plate will also help circulate cool air through the Switch.

# MANAGING THE MODULE

When the Module is installed, you can configure it through your Switch to add extra functionality. Refer to the documentation that accompanies your Switch 4400 for more information.

# MODULE PORT RESTRICTIONS

When using the Module port, note the following:

- The Module only operates at 1000 Mbps.
- The Module only operates when connected to another 1000BASE-SX device.
- The Module only operates in full duplex mode.
- The Module is not hot-swappable.
- The Module is not hot-insertable.
- The Module only operates with multimode fiber optic cable.

# PROBLEM SOLVING

If you suspect a problem, carry out these steps *before* contacting your supplier:

- Ensure that the Module is correctly installed in the Switch.
- Ensure that the Switch in which the Module is fitted is powered-up.
- Ensure that the device at the far end of the link is powered-up and operating correctly.
- Check that all connectors on the fiber optic segment are correctly engaged.
- Clean the terminators by wiping them gently with a clean tissue or cotton bud moistened with a little ethanol. Dirty fiber terminators on the fiber optic segment impair the quality of the light transmitted through the cable.

For information about technical support, refer to the documentation supplied with your Switch.

# TECHNICAL SUPPORT

The following options are available for technical support:

- In the first instance contact your Network Supplier
- Check the 3Com knowledgebase at <http://knowledgebase.3com.com>
- Browse the 3Com web site on <http://www.3com.com>

Please have your product model name, part number, hardware revision number and serial number along with all relevant details of the problem to hand before calling your Network Supplier or 3Com on the numbers below.

Country	Telephone Number	Country	Telephone Number	Country	Telephone Number
<b>Asia, Pacific Rim</b>				<b>Latin America</b>	
Australia	1 800 678 515	P.R. of China	10800 61 00137 or	Brazil	0800 13 3266
Hong Kong	800 933 486		021 6350 1590 or	Mexico	01 800 849CARE
India	+61 2 9937 5085 or 000800 6501111	Singapore	00800 0638 3266	Puerto Rico	800 666 5065
Indonesia	001 800 61 009	S. Korea:	800 6161 463	Central and South America	AT&T +800 998 2112
Japan	03 5783 1270		00798 611 2230 or		
Malaysia	1800 801 777	Taiwan, R.O.C.	02 3455 6455		
New Zealand	0800 446 398	Thailand	00798 611 2230		
Pakistan	+61 2 9937 5083		0080 611 261		
Philippines	1235 61 266 2602		001 800 611 2000		
<b>Europe, Middle East and Africa</b>					
From anywhere in these regions, call:	+44 (0)1442 435529 phone +44 (0)1442 436722 fax				
<b>Europe and South Africa</b> From the following countries, you may use the following toll-free numbers:					
Austria	0800 297468	Ireland	1800 553117	Portugal	0800 831416
Belgium	0800 71429	Israel	1800 9453794	South Africa	0800 995014
Denmark	800 17309	Italy	800 8 79489	Spain	900 983125
Finland	0800 113153	Luxembourg	0800 3625	Sweden	020 795482
France	0800 917959	Netherlands	0800 0227788	Switzerland	0800 55 3072
Germany	0800 1821502	Norway	800 11376	U.K.	0800 966197
Hungary	06800 12813	Poland	00800 3111206		
<b>North America</b>					
	1 800 NET 3Com (1 800 638 3266) Enterprise Customers: 1 800 876 3266				

# TECHNICAL SPECIFICATIONS

<b>Operating Temperature</b>	0 to 40°C (32 to 105°F)
<b>Operating Humidity</b>	10 to 95% non-condensing
<b>Power Consumption</b>	1.5 W maximum
<b>Safety Standards</b>	UL 1950 EN 60825-1 & EN 60950 CSA 22.2#950 IEC 60950

<b>Electromagnetic Compatibility</b>	CISPR22 Class A EN55022 Class A AS/NZS 3548 Class A FCC Part 15 Class A ICES-003 Class A VCCI Class A CNS 13438 Class A Korean EMC Approval EN55024
--------------------------------------	---

## REGULATORY NOTICES

### FCC Statement

This equipment has been tested and found to comply with the limits for a Class A digital device, pursuant to part 15 of the FCC rules. These limits are designed to provide reasonable protection against harmful interference when the equipment is operated in a commercial environment. This equipment generates, uses and can radiate radio frequency energy and, if not installed and used in accordance with the instructions, may cause harmful interference to radio communications. Operation of this equipment in a residential area is likely to cause harmful interference to radio communications, in which case the user will be required to correct the interference at their own expense.

### Information To The User

If this equipment does cause interference to radio or television reception, which can be determined by turning the equipment off and on, the user is encouraged to try to correct the interference by one or more of the following measures:

- Reorient the receiving antenna.
- Relocate the equipment in relation to the receiver.
- Move the equipment away from the receiver.
- Plug the equipment into a different outlet so that equipment and receiver are on different branch circuits.

If necessary, the user should consult the dealer or an experienced radio/television technician for additional suggestions. The user may find the following booklet prepared by the Federal Communications Commission helpful:

*How to Identify and Resolve Radio-TV Interference Problems*

This booklet is available from the U.S. Government Printing Office, Washington, DC 20402, Stock No. 004-000-00345-4.

In order to meet FCC emissions limits, this equipment must be used only with cables which comply with IEEE 802.3.

### CE Statement (Europe)

This product complies with the European Low Voltage Directive 73/23/EEC and EMC Directive 89/336/EEC as amended by European Directive 93/68/EEC.

### CSA Statement

This Class A digital apparatus meets all requirements of the Canadian interference-Causing Equipment Regulations.

Cet appareil numérique de la classe A respecte toutes les exigences du Règlement sur le matériel brouilleur du Canada.

### VCCI Statement

この装置は、情報処理装置等電波障害自主規制協議会（VCCI）の基準に基づくクラスA情報技術装置です。この装置を家庭環境で使用すると電波妨害を引き起こすことがあります。この場合には使用者が適切な対策を講ずるよう要求されることがあります。

### BSMI Statement

警告使用者：這是甲類的資訊產品，在居住的環境中使用時，可能會造成射頻干擾，在這種情況下，使用者會被要求採取某些適當的對策。

# LEGAL NOTICES

© 3Com Technologies, 2001. All rights reserved. No part of this documentation may be reproduced in any form or by any means or used to make any derivative work (such as translation, transformation, or adaptation) without permission from 3Com Technologies.

3Com Technologies reserves the right to revise this documentation and to make changes in content from time to time without obligation on the part of 3Com Technologies to provide notification of such revision or change.

3Com Technologies provides this documentation without warranty of any kind, either implied or expressed, including, but not limited to, the implied warranties of merchantability and fitness for a particular purpose. 3Com may make improvements or changes in the product(s) and/or the program(s) described in this documentation at any time.

## UNITED STATES GOVERNMENT LEGENDS:

If you are a United States government agency, then this documentation and the software described herein are provided to you subject to the following restricted rights:

### For units of the Department of Defense:

*Restricted Rights Legend:* Use, duplication or disclosure by the Government is subject to restrictions as set forth in subparagraph (c) (1) (ii) for restricted Rights in Technical Data and Computer Software clause at

48 C.F.R. 52.227-7013. 3Com Centre, Boundary Way, Maylands Park South, Hemel Hempstead, Herts, HP2 7YU, U.K.

### For civilian agencies:

*Restricted Rights Legend:* Use, reproduction or disclosure is subject to restrictions set forth in subparagraph (a) through (d) of the Commercial Computer Software - Restricted Rights Clause at 48 C.F.R. 52.227-19 and the limitations set forth in 3Com Corporation's standard commercial agreement for the software. Unpublished rights reserved under the copyright laws of the United States.

If there is any software on removable media described in this documentation, it is furnished under a license agreement included with the product as a separate document, in the hard copy documentation, or on the removable media in a directory file named LICENSE.TXT. If you are unable to locate a copy, please contact 3Com and a copy will be provided to you.

Unless otherwise indicated, 3Com registered trademarks are registered in the United States and may or may not be registered in other countries.

3Com and SuperStack are registered trademarks of 3Com Corporation.

Other brand and product names may be registered trademarks or trademarks of their respective holders.

# ENVIRONMENTAL STATEMENTS

## General Environmental Statement

It is the policy of 3Com Corporation to be environmentally-friendly in all operations. To uphold our policy, we are committed to:

- Establishing environmental performance standards that comply with national legislation and regulations
- Conserving energy, materials and natural resources in all operations
- Reducing the waste generated by all operations
- Ensuring that all waste conforms to recognized environmental standards
- Maximizing the recyclable and reusable content of all products
- Ensuring that all products can be recycled, reused and disposed of safely
- Ensuring that all products are labelled according to recognized environmental standards
- Improving our environmental record on a continual basis

## End Of Life Statement

3Com processes allow for the recovery, reclamation and safe disposal of all end-of-life electronic components.

## Regulated Materials Statement

3Com products do not contain any hazardous or ozone-depleting material.

## Environmental Statement about the Documentation

The documentation for this product is printed on paper that comes from sustainable, managed forests; it is fully biodegradable and recyclable, and is completely chlorine-free. The varnish is environmentally-friendly, and the inks are vegetable-based with a low heavy-metal content.

## Product Registration

You can now register your 1000BASE-SX Module on the 3Com web site at:

<http://support.3com.com/registration/frontpg.pl>

## Documentation Feedback

Your suggestions are very important to us. They will help make our documentation more useful to you. Please e-mail comments about this document to 3Com at:

[pddtechpubs\\_comments@3Com.com](mailto:pddtechpubs_comments@3Com.com)

Please include the following information when commenting: the document title, part number, and page number, if appropriate.

Part Number: DUA1722-1AAA01

Rev: 02

Published: March 2001