

Product End-of-Life Disassembly Instructions
Product Category: *Networking*
Marketing Name / Model

[List multiple models if applicable.]

HPE FlexFabric 12900E 36-Port 40GbE QSFP+ Type X Module (JL847A)

Purpose: The document is intended for use by end-of-life recyclers or treatment facilities. It provides the basic instructions for the disassembly of HPE products to remove components and materials requiring selective treatment, as defined by Directive 2012/19/EU of the European Parliament and of the Council on Waste Electrical and Electronic Equipment (WEEE).

1.0 Items Requiring Selective Treatment

1.1 Items listed below are classified as requiring selective treatment.

1.2 Enter the quantity of items contained within the product which require selective treatment in the right column, as applicable.

Item Description	Notes	Quantity of items included in product
Printed Circuit Boards (PCB) or Printed Circuit Assemblies (PCA)	With a surface greater than 10 sq cm	3
Batteries	All types including standard alkaline and lithium coin or button style batteries	0
Mercury-containing components	For example, mercury in lamps, display backlights, scanner lamps, switches, batteries	0
Liquid Crystal Displays (LCD) with a surface greater than 100 sq cm	Includes background illuminated displays with gas discharge lamps	0
Cathode Ray Tubes (CRT)		0
Capacitors / condensers (Containing PCB/PCT)		0
Electrolytic Capacitors / Condensers measuring greater than 2.5 cm in diameter or height		0
External electrical cables and cords		0
Gas Discharge Lamps		0
Plastics containing Brominated Flame Retardants		0
Components and parts containing toner and ink, including liquids, semi-liquids (gel/paste) and toner	Include the cartridges, print heads, tubes, vent chambers, and service stations.	0
Components and waste containing asbestos		0

Item Description	Notes	Quantity of items included in product
Components, parts and materials containing refractory ceramic fibers		0
Components, parts and materials containing radioactive substances		0

2.0 Tools Required

List the type and size of the tools that would typically be used to disassemble the product to a point where components and materials requiring selective treatment can be removed.

Tool Description	Tool Size (if applicable)
Screwdriver	#2
Hexagonal socket wrench	M3

3.0 Product Disassembly Process

3.1 List the basic steps that should typically be followed to remove components and materials requiring selective treatment:

1. Remove the film 1.
2. Unscrew the screws on part 2, and then remove part 2.
3. Unscrew the screws on pcb 6/8/13, and then remove pcb 6/8/13.
4. Unscrew the screws on heatsink 7, and then remove heatsink 7.
5. Unscrew the screws on part 12, and then remove part 12.
6. Unscrew the DIMM 11 on part 14.
7. Unscrew the screws on part 14, and then remove part 14, and then remove heatsink from part 14.
8. Unscrew the screws on part 3, and then remove part 3 from part 15.
9. Unscrew part 10 and other screws on part 5, and then remove part 5 from part 15.
10. Remove part 4 from part 5.
11. Unscrew the screws on part 9, and then remove part 9 from part 5.

3.2 Optional Graphic. If the disassembly process is complex, insert a graphic illustration below to identify the items contained in the product that require selective treatment (with descriptions and arrows identifying locations).

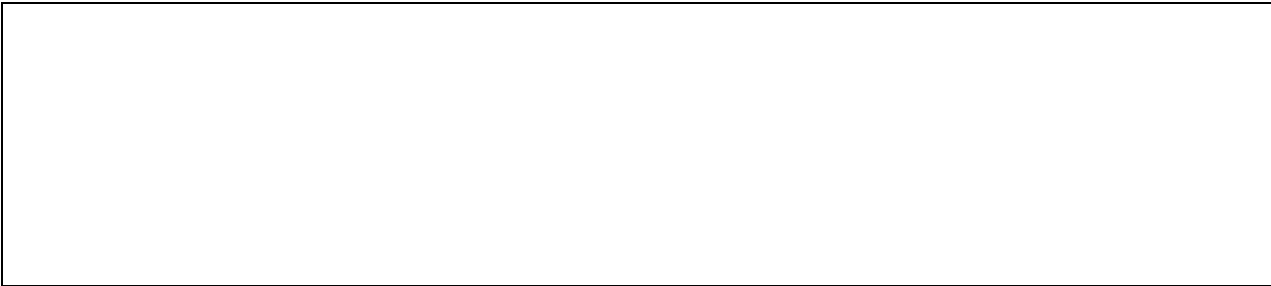

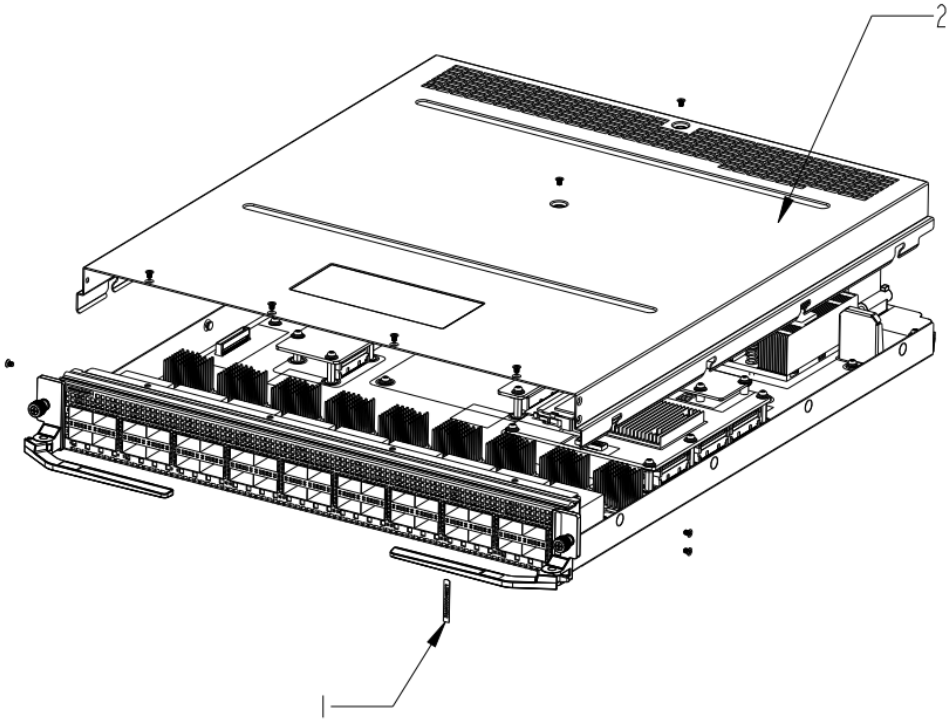

Figure 1 Treatments to the product

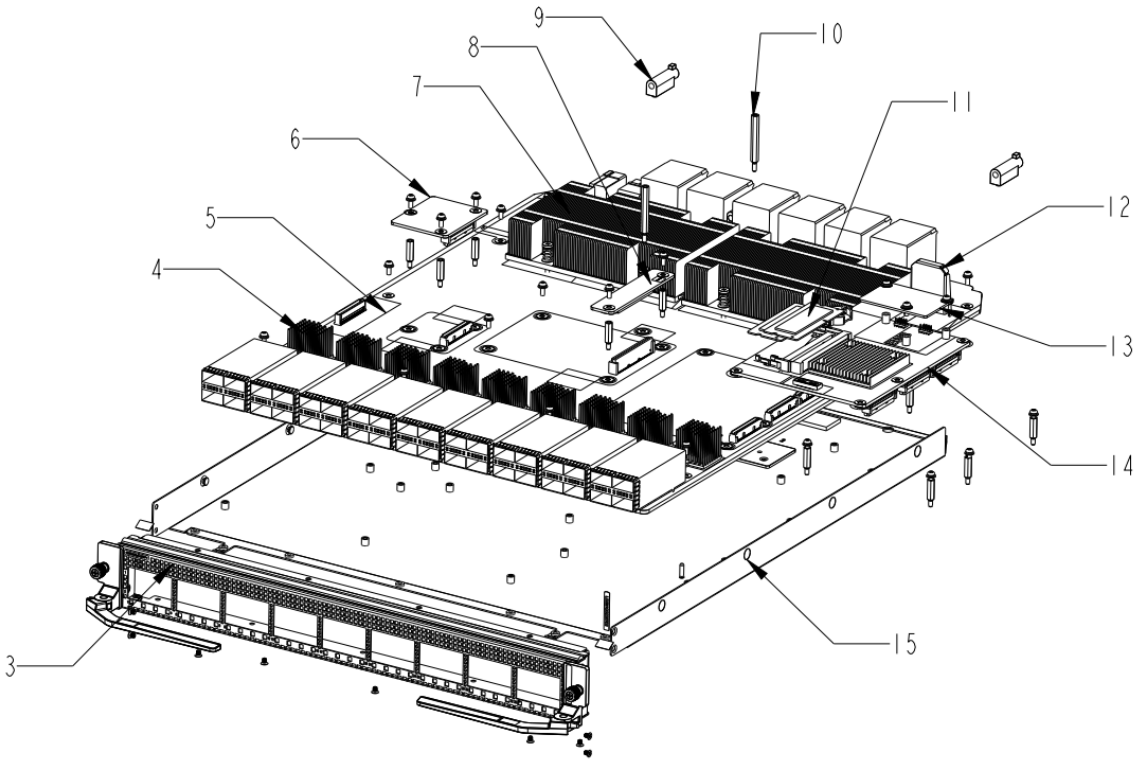

Figure 2 Treatments to the product