

Product End-of-Life Disassembly Instructions

Product Category: Networking Equipment

Marketing Name / Model

[List multiple models if applicable.]

HPE 5710 48XGT 6QS+/2QS28 Switch(JL586A)

HPE 5710 24XGT 6QS+/2QS28 Switch(JL689A)

Purpose: The document is intended for use by end-of-life recyclers or treatment facilities. It provides the basic instructions for the disassembly of HPE products to remove components and materials requiring selective treatment, as defined by EU directive 2012/19/EC, Waste Electrical and Electronic Equipment (WEEE).

1.0 Items Requiring Selective Treatment

1.1 Items listed below are classified as requiring selective treatment.

1.2 Enter the quantity of items contained within the product which require selective treatment in the right column, as applicable.

Item Description	Notes	Quantity of items included in product
Printed Circuit Boards (PCB) or Printed Circuit Assemblies (PCA)	With a surface greater than 10 sq cm	4
Batteries	All types including standard alkaline and lithium coin or button style batteries	0
Mercury-containing components	For example, mercury in lamps, display backlights, scanner lamps, switches, batteries	0
Liquid Crystal Displays (LCD) with a surface greater than 100 sq cm	Includes background illuminated displays with gas discharge lamps	0
Cathode Ray Tubes (CRT)		0
Capacitors / condensers (Containing PCB/PCT)		0
Electrolytic Capacitors / Condensers measuring greater than 2.5 cm in diameter or height		0
External electrical cables and cords		0
Gas Discharge Lamps		0
Plastics containing Brominated Flame Retardants weighing > 25 grams (not including PCBs or PCAs already listed as a separate item above)		0
Components and parts containing toner and ink, including liquids, semi-liquids (gel/paste) and toner	Include the cartridges, print heads, tubes, vent chambers, and service stations.	0
Components and waste containing asbestos		0
Components, parts and materials containing refractory ceramic fibers		0
Components, parts and materials containing radioactive substances		0

2.0 Tools Required

List the type and size of the tools that would typically be used to disassemble the product to a point where components and materials requiring selective treatment can be removed.

Tool Description	Tool Size (if applicable)
Phillips screwdriver	2#

3.0 Product Disassembly Process

3.1 List the basic steps that should typically be followed to remove components and materials requiring selective treatment:

1. Remove the blank panel 1.
2. Remove film 1-1 from panel 1-2.
3. Unscrew the screws 2 and remove top cover 3.
4. Remove foams 3-1 and labels 3-2, 3-3, 3-4, 3-5 from top cover.
5. Unscrew the screws 4,5 and remove PCB 6,7.
6. Unscrew the screws 7-1,7-2 and remove PCB 7-3 from PCB 7-4.
7. Unscrew the screws 8 and remove radiator 9, remove fan transit cables 10.
8. Unscrew the screws 11,12,13 and remove PCB 14.
9. Remove dowel 14-1, dowel bushing 14-2, spring 14-3, radiator 14-4 and film 14-5 from pcb 14-6.
10. Remove foam 15 and film16 .
11. Remove film 17 from mounting bracket 18.

3.2 Optional Graphic. If the disassembly process is complex, insert a graphic illustration below to identify the items contained in the product that require selective treatment (with descriptions and arrows identifying locations).

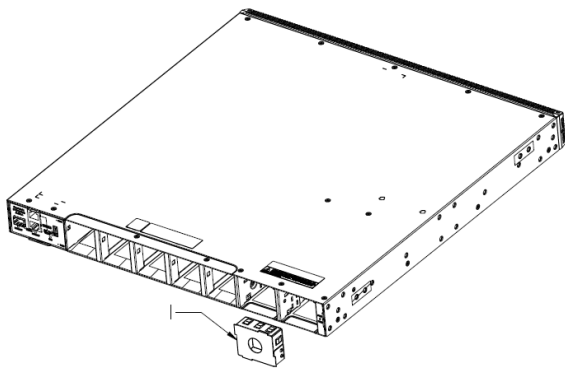

Figure 1 Remove blank panel

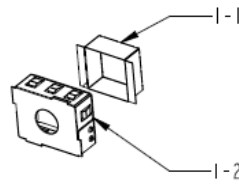

Figure 2 Treatments to blank panel

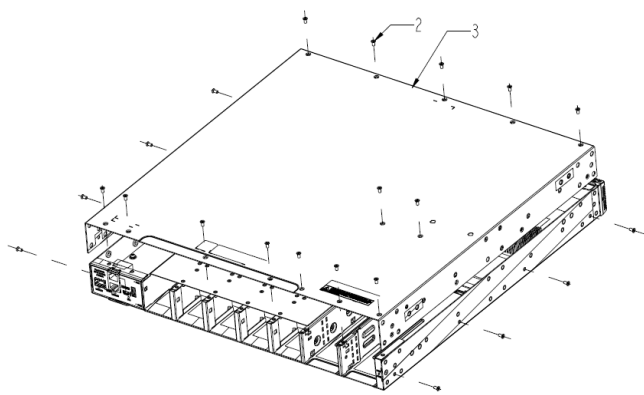

Figure 3 Remove the top cover

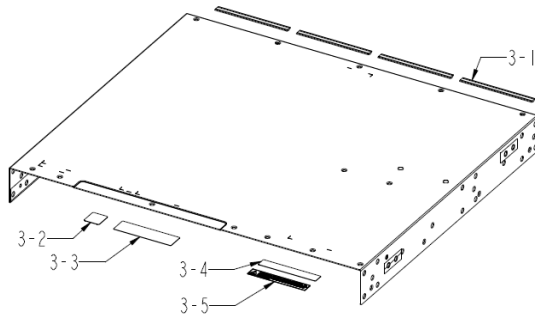

Figure 4 Treatments to the top cover

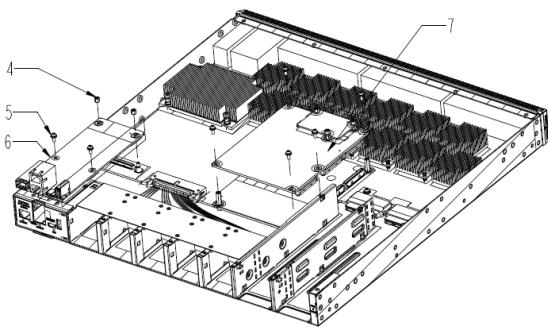

Figure 5 Treatments to the product

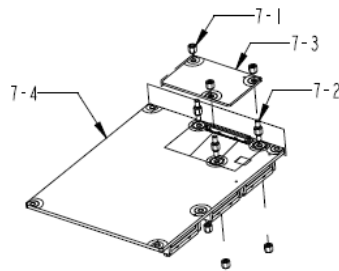

Figure 6 Treatments to the PCB 7

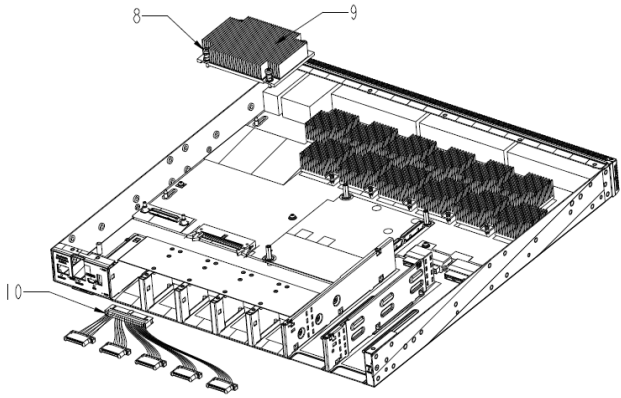

Figure 7 Treatments to the product

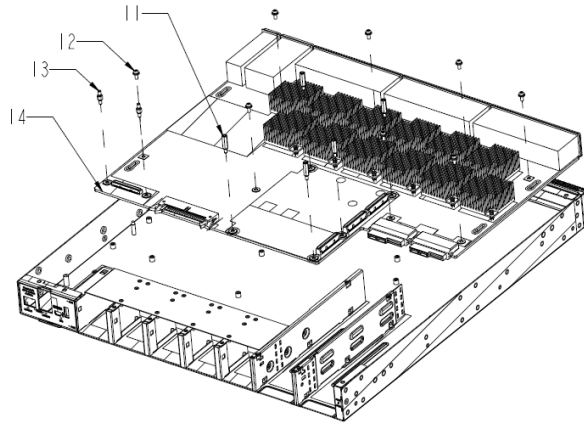

Figure 8 Treatments to the product

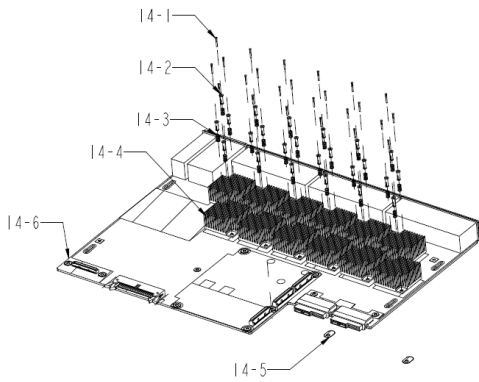

Figure 9 Treatments to the PCB14

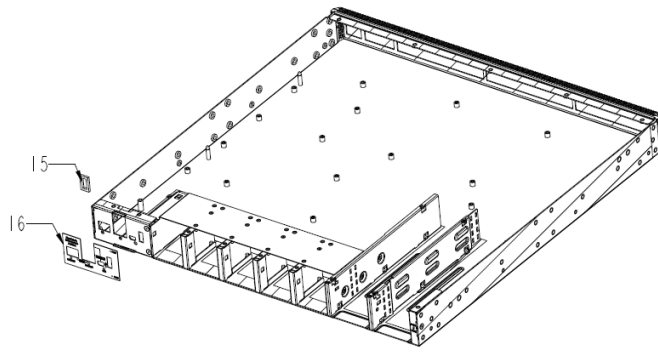

Figure 10 Treatments to the product

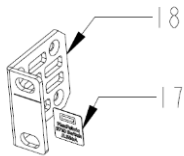

Figure 11 Treatments to the film 17