

Overview

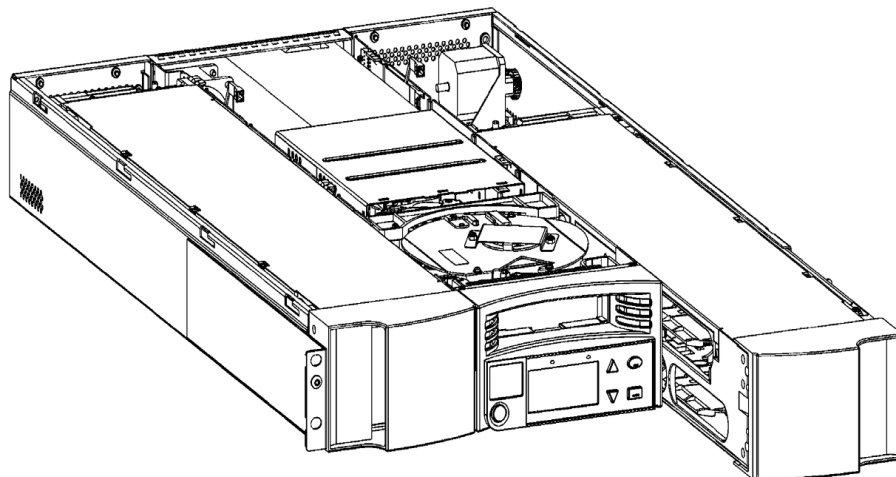

Introduction

The HP StorageWorks SSL1016 tape autoloader combines library features and capacity in the compact form of an autoloader. Ideal for replicated systems, the web-based management feature reduces dependence on local IT resources allowing multiple sites to be supported centrally. With a native capacity of up to 3.2 TB, the SSL1016 easily replaces a small library for many applications. At 2U in height, it provides a large amount of storage without consuming a large amount of valuable rack space.

What's New

Allows HP Factory Express racking capability through the use of a factory integration option (#OD1)

Models

HP StorageWorks SSL1016 Tape Autoloader Models	SSL1016 Ultrium 460 Tape Autoloader NOTE: One Ultrium 460 drive, 16-slot autoloader, rack-ready model; includes remote management card, barcode reader and tabletop conversion kit.	330821-B21
	SSL1016 SDLT 320 Tape Autoloader NOTE: One SDLT 320 drive, 16-slot autoloader, rack-ready model; includes remote management card, barcode reader and tabletop conversion kit.	330816-B21

Key Features

- Remote web management
- Native capacity up to 3.2 TB with Ultrium 460 tape drive
- Native data transfer rate up to 30 MB/s with Ultrium 460 tape drive
- 2U form factor (rack mount or tabletop)
- 16 cartridge capacity with user-selectable import/export slot
- Integrated bar code reader
- Two eight-cartridge removable magazines
- Modular design for easier maintenance and upgrade capabilities
- Two 8-cartridge removable magazines

Overview

Customer Benefits

- **Manageable:** web-based remote manageability allows monitoring and management from anywhere in the world
- **Automated:** features a standard bar code reader for improved media management
- **Compact:** saves valuable rack space with 2U form factor
- **High-capacity:** stores up to 3.2 TB (native) of data with Ultrium 460 technology
- **Efficient:** uses two removable eight-slot magazines for bulk-loading of tape media
- **Affordable:** provides library features in the form factor and price range of a tape autoloader
- **Diverse:** supports Ultrium 460 and SDLT 320 drive technologies
- **Reliable:** modular design allows quick repair to reduce product downtime
- **Integrated:** ability to factory rack integrate with other HP products such as HP ProLiant Servers
- **Compatible:** runs with leading servers, operating systems and backup software

Family Comparison	SSL1016 Ultrium 460 Tape Autoloader	SSL1016 SDLT 320 Tape Autoloader
Drive Technology	Ultrium 460	SDLT 320
Capacity (native)	3.2 TB	2.56 TB
Maximum Data Transfer (native)	30 MB/s	16 MB/s
SCSI Interface	Ultra3 SCSI LVD/SE	Ultra2 SCSI LVD/SE

Product Highlights

Capacity	<p>The SSL1016 Tape Autoloader family offers different capacity points:</p> <ul style="list-style-type: none">• The SSL1016 Ultrium 460 Tape Autoloader supports 16 data cartridges for a total capacity of 3.2 TB (native).• The SSL1016 SDLT 320 Tape Autoloader supports 16 data cartridges for a total capacity of 2.56 TB (native).
Easy Installation	<p>The SSL1016 Tape Autoloader is shipped as a rack-ready unit; ready for installation in a standard 19" rack. A tabletop conversion kit is also included in the box for those customers who choose to use the autoloader on a desktop.</p>
HP Factory Express Capability	<p>HP Factory Express gives the customer the flexibility to choose from a full menu of factory capabilities all in one manufacturing facility, in one process, with one touch. It gives the customer full control and access to HP's world-class manufacturing facilities anytime. This approach provides the customer with the speed to deploy his or her IT needs, with total quality assurance, reliability and predictability to lower the total cost of ownership; allowing HP to install, rack and customize the software and hardware options the customer has chosen.</p>
Manageability	<p>The SSL1016 Tape Autoloader allows web-based remote manageability; the unit can be monitored and managed from across the room or across the globe. Functions included in the management tool include:</p> <ul style="list-style-type: none">• Status information on the drive and system• System configuration operations and reporting• System error and status logs• Library and drive firmware upload capabilities• Language support through firmware upgrades• Diagnostic tests and information• Cartridge movement for maintenance and management purposes• Cleaning cartridge support• Security and access control• SNMP support for IP communications
LTO Ultrium Technology	<p>HP StorageWorks LTO (Linear Tape Open) Ultrium Tape Drives use best of breed technology. By taking the best features from other tape technologies and combining them into a single new technology, Ultrium tape drives are in a league of their own. Inclusion of innovative features such as Adaptive Tape Speed (ATS) ensure that Ultrium drives can meet the performance and reliability demands of a library environment. LTO technology is an open industry standard format; thus data written on HP StorageWorks Ultrium Tape Drives can be interchanged directly with Ultrium Tape Drives from other vendors.</p>
Performance	<p>The SSL1016 Tape Autoloader family offers different performance points:</p> <ul style="list-style-type: none">• Utilizing an HP StorageWorks Ultrium 460 drive, the SSL1016 Tape Autoloader can transfer data at 30 MB/s or 108 GB/hr (native).• Utilizing an HP StorageWorks SDLT 320 drive, the SSL1016 Tape Autoloader can transfer data at 16 MB/s or 57.6 GB/hr (native).

Product Highlights

SDLT Technology

DLT (digital linear tape) uses a proven linear recording technology, a highly accurate tape guide system, and a read after write correction system to provide high-capacity, high reliability data backup and restoration. DLT has fast become the industry-standard secondary storage tape format for departmental and enterprise backup. The new generation SDLT tape drive, provides enhanced capacity and backup performance and includes several new features such as laser guided magnetic recoding (LGMR) technology, pivoting optical servo (POS), magneto-resistive cluster heads (MRC), partial response maximum likelihood (PRML) channel technology and backward-read compatibility with earlier generations of DLT drives (to be able to read media written in DLT type IV format).

Serviceability

Modular in construction, the SSL1016 Tape Autoloader has easily replaceable components minimizing the Mean-Time-to-Repair on the unit. Replaceable components include the drive/power supply/controller board, the magazines, and the chassis/robot.

HP StorageWorks Library and Tape Tools (L&TT) provides easy access to the SSL1016 Tape Autoloader error log, generates support tickets, and enables firmware downloads. L&TT can be downloaded for free at <http://www.hp.com/support/tapetools>

Software Components

HP StorageWorks Library and Tape Tools The SSL1016 Tape Autoloader is supported on HP's industry-leading diagnostic tool - HP StorageWorks Library and Tape Tools (L&TT). L&TT is a single, convenient program that's a snap to install and simple to operate. L&TT's intuitive user interface eliminates the need for training and deploys in less than five minutes. This robust diagnostic tool is designed for both the experienced professional and the untrained administrator. It ensures product integrity through self-diagnostics and fast resolution to device concerns. Additional information on L&TT plus download information can be found at <http://www.hp.com/support/tapetools>.

Insight Manager The SSL1016 Tape Autoloader is supported for use with Insight Manager 7.0 and above.

Compatibility

HP's extensive compatibility testing program assures that your HP StorageWorks SSL1016 Tape Autoloader works with leading servers, operating systems, and backup applications - and not just those sold by HP. The SSL1016 Tape Autoloader works seamlessly in many environments, making them especially suitable if you have a mixed system environment. For the latest list of servers, workstations, operating systems, and backup software that support HP StorageWorks SSL1016 Tape Autoloader, check the tape backup compatibility pages on our web site at <http://www.hp.com/go/ebs>.

HP Server Compatibility The HP StorageWorks SSL1016 Tape Autoloader is supported on a wide range of HP systems. For details of which SSL1016 Tape Autoloader works with which systems, including third-party systems, reference the EBS compatibility matrix at <http://www.hp.com/go/ebs> for the latest hardware compatibility information.

OS Support Reference the EBS compatibility matrix for the most up-to-date OS compatibility information at <http://www.hp.com/go/ebs>.

Software Support Reference the EBS compatibility matrix for the most up-to-date software compatibility information at <http://www.hp.com/go/ebs>.

Service and Support, HP Care Pack, and Warranty Information

Warranty The warranty for this product consists of 1-year parts exchange.

Warranty Upgrade Options Response - Upgrade on-site response from next business day to same day 4 hours
Coverage - Extend hours of coverage from 13 hours x 5 days to 24 hours x 7 days
Duration - Select duration of coverage for a period of 1 or 3 years

HP Care Pack Information

- HP Care Pack is defined as an upgrade to the product warranty attribute, available for a specific duration and hours of coverage
- HP Care Pack is not available for less than the product's warranty duration
- HP Care Pack is available for sale anytime during the warranty period for most products, but the commencement date will be the same as the Warranty Start Date (delivery date to end user customer). Proof of purchase may be required
- HP Care Pack services are prepaid
- For additional HP Care Pack (hardware and software) information, as well as orderable part numbers, please refer to the URL listed below:
<http://www.hp.com/hps/carepack/>

Software Product Services Standalone telephone support
Media and documentation updates

Hardware Product Services Installation services
On-site maintenance (includes warranty support)
Response time upgrades during the warranty period
Post-warranty coverage
For additional hardware installation and maintenance information, please refer to the URL listed below:
<http://www.hp.com/hps/hardware/>

Support Services HP Services provides a three-year, limited warranty, fully supported by a worldwide network of resellers and service providers and 9x5 hardware technical phone support during the warranty period. In addition, available service offerings include a full range of optional packaged hardware and software services:

- Installation and start up
- Extended coverage hours and enhanced response times
- System management and performance services
- Availability and recovery services

Components The following brick level options/components do not have individual HP Care Pack Services. These items will be included in product HP Care Pack Services into which they are installed.

Disk Drives	Tape Drives	CD/DVD ROM	SCSI Hubs in SBBs	Adapters
Bus Converters	Backplane RAID Controllers	Power Supplies	Cabling	Fans

Configuration Information

NOTE: The HP StorageWorks SSL1016 Tape Autoloader comes standard as a one drive, 16-slot unit which is shipped rack-ready. A U.S. power cord and tabletop installation kit is included in the box. For any other specific regional power cord requirements, a separate power cord must be ordered.

Step 1 - SSL1016 Tape Autoloader-Base Configuration

Select one:

Model Name	Model Description	Part Number
SSL1016 Ultrium 460	HP StorageWorks SSL1016 Ultrium 460 Tape Autoloader	330821-B21
SSL1016 SDLT 320	HP StorageWorks SSL1016 SDLT 320 Tape Autoloader	330816-B21

Kit Contents (for each autoloader):

- (1) 6' US/Canada/Mexico power cord (IEC320-C13 to NEMA 5-15P)
- (1) data cartridge (specific to tape drive)
- (1) 2.5M VHDCI to VHDCI SCSI cable
- (1) RJ-45 Ethernet cable
- (1) VHDCI SCSI terminator
- (1) tabletop installation kit
- (1) rackmount installation kit (for use with HP E series rack or HP 10000 rack cabinet)
- Bar code label sample pack specific to drive type (label quantity varies by drive type)
- Documentation kit including manual (CD), quick start poster, warranty card, safety card, HP OpenView Storage Data Protector flier

Step 2: Required Options

Select each required option with quantities specified:

Power Cord	Description with Parts Shipped	Quantity	Part Number
	Power Cord, (Australia/China/New Zealand)	1 each	227098-011
	Power Cord, (South East Asia/India)	1 each	157220-AR1
	Power Cord, (Central Europe)	1 each	157215-021
	Power Cord, (United Kingdom/Hong Kong/Singapore)	1 each	157216-031
	Power Cord, (Switzerland)	1 each	157219-111
	Power Cord, (Italy)	1 each	157217-061
	Power Cord, (Denmark)	1 each	157218-081
	Power Cord, (Japan)	1 each	AD531A

NOTE: One power cord is required. Please select the correct power cord for your geographical location.

WARNING: This product can ONLY be used with an HP approved power cord for your specific geographic region. Use of a non-HP approved power cord may result in: 1) not meeting individual country specific safety requirements; 2) insufficient conductor ampacity that could result in overheating with potential personal injury and/or property damage; and 3) an unapproved power cord could fracture resulting in the internal contacts being exposed, which potentially could subject the user to a shock hazard. HP disclaims all liability in the event a non-HP approved power cord is used.

Related Options

Factory Racking	Factory integrate the SSL1016 Tape Autoloader with other HP products such as HP ProLiant Servers. NOTE: #0D1 will appear after the 1/8 Tape Autoloader part number on the sales order if HP factory integration is indicated.	
Magazine Kits	Additional 8-slot magazine for use in the SSL1016 Ultrium 460 Tape Autoloader	330823-B21
	Additional 8-slot magazine for use in the SSL1016 SDLT 320 or DLT1 Tape Autoloader	268664-B22
Media	HP Ultrium 400 GB data cartridge (1 pack)	C7972A
	HP Ultrium universal cleaning cartridge (1 pack)	C7978A
	HP Ultrium 2 bar code labels (100 pack)	Q2002A
	HP Ultrium 400GB pre-labeled data cartridge, 20pk (NA only)	C7972AL
	HP Ultrium 400GB pre-labeled data cartridge, 1pk (Europe only)	C7972L
	HP SDLT 320 GB data cartridge (1 pack)	C7980A
	HP SDLT cleaning cartridge (1 pack)	C7982A
	HP SDLT bar code labels (100 pack)	Q2003A
	HP SDLT pre-labeled data cartridge, 20pk (NA only)	C7980AL
	HP SDLT pre-labeled data cartridge, 1pk (Europe only)	C7980L
Rack Cabinets	10622 (22U) Rack Cabinet - Shock Pallet	245163-B22
	10636 (36U) Rack Cabinet - Shock Pallet	245162-B22
	10642 (42U) Rack Cabinet - Shock Pallet	245161-B22
	NOTE: The SSL1016 Tape Autoloader is certified to ship in HP 10000 series racks which include a shock pallet. It is mandatory to use a shock pallet in order to ship racks with equipment installed.	
	5642 (42U) Rack Cabinet	358254-B21
	NOTE: This rack ships unassembled and boxed on a standard size pallet. It is an industry standard 19" wide rack with side panels and rear doors; does not ship with the front door or casters.	
Host Bus Adapters	Reference the EBS matrix for the most up-to-date SCSI HBA compatibility information at http://www.hp.com/go/ebs	
Cable Kits	Reference the Data Cable data sheets for the most up-to-date cable information at: http://iss.tsgonline.hp.com/Document_Storage/collateral/ds_scsimultimode.pdf	

Related Options

HP Care Pack Options

Same Day Response

Warranty upgrade to 1-year, 13x5, 4 hour response/onsite	U6364A
Warranty upgrade to 1-year, 13x5, 4 hour response/onsite, electronic	U6364E
Warranty upgrade to 1-year, 24x7, 4 hour response/onsite	U6365A
Warranty upgrade to 1-year, 24x7, 4 hour response/onsite, electronic	U6365E
Warranty upgrade to 3-year, 13x5, 4 hour response/onsite	H5526A
Warranty upgrade to 3-year, 13x5, 4 hour response/onsite, electronic	H5526E
Warranty upgrade to 3-year, 24x7, 4 hour response/onsite	H4624A
Warranty upgrade to 3-year, 24x7, 4 hour response/onsite, electronic	H4624E

Next Business Day Response

Warranty upgrade to 3-year next business day/parts exchange	H2698A
Warranty upgrade to 3-year next business day/parts exchange, electronic	H2698E
Warranty upgrade to 3-year next business day/onsite	H4619A
Warranty upgrade to 3-year next business day/onsite, electronic	H4619E

Hardware Services

Installation services	U2090A
Installation services, electronic	U2090E

NOTE: 'A' signifies a physical HP Care Pack; 'E' signifies an electronic HP Care Pack.

Technical Specifications

	SSL1016 Ultrium 460	SSL1016 SDLT 320
Drive Technology	Ultrium 460	SDLT 320
Capacity	3.2 TB native 6.4 TB compressed	2.56 TB native 5.12 TB compressed
Interface	Ultra3 SCSI LVD/SE	Ultra2 SCSI LVD/SE
Maximum Transfer Rate	30 MB/s (108 GB/hr) - native 60 MB/s (216 GB/hr) - compressed	16 MB/s (57.6 GB/hr) - native 32 MB/s (115.2 GB/hr) - compressed
Reliability	1,000,000 mean swaps between failures (MSBF)	
Dimensions (HxWxD)	Out-of-Box Shipping	3.5 x 17.7 x 29.71 in (8.89 x 44.96 x 75.46 cm) 11.75 x 23.5 x 39.5 in (29.8 x 59.7 x 100.3 cm)
Weight (HxWxD)	Out of Box Shipping	50 lb (22.73 kg); not including media 68.2 lb (31 kg)
Connectors/Cables	Connectors Cables	(2) 68-pin VHDCI; (1) RJ-45 (both on rear of SSL1016 autoloader) (1) 2.5M VHDCI to VHDCI SCSI cable (1) RJ-45 Ethernet cable
Input Requirements	100 to 240 VAC, 50 to 60 Hz, 1.0 Amperes	
Inventory Time	22 seconds	
LED Indicators (On Front Panel)	Left (Green) LED shows ready status information Right (Amber) LED shows fault status information	
Power	80 Watts (max)	
Relative Humidity (non-condensing)	Operating Shipping	20 % to 80% 10 % to 90%
Temperature Range	Operating Shipping	50° to 95° F (10° to 35° C) -40° to 149° F (-40° to 65° C)

© Copyright 2003-2005 Hewlett-Packard Development Company, L.P.

The information contained herein is subject to change without notice.

The only warranties for HP products and services are set forth in the express warranty statements accompanying such products and services. Nothing herein should be construed as constituting an additional warranty. HP shall not be liable for technical or editorial errors or omissions contained herein.